

Finding the lowest values of the dimensions  
of differently shaped storage rooms using  
differential calculus and optimization.

Mathematical Studies SL

### **Introduction**

Optimization and differential calculus are very helpful in determining a certain maximum or minimum value at a certain point in time.

If I wanted to construct a storage room, I could use optimization and differential calculus to help me consider the shape of the room. By using volume formulas to aid me in differentiating area formulas and finding the minimum amount I would spend, I can see how much I would expect to pay for the walls of the room. I also need to consider the cost of my materials, and the overall capacity of the room. Upon choosing galvanized steel for \$10 per square meter, I set out to see what shape would give me the lowest cost for the walls of a capacity of  $36\text{m}^3$  with differential calculus and optimization. The three types of structure I will examine are:

- a) A boxed room with a square floor,
- b) A rectangular based room with a ration of 2:1 &
- c) A cylindrical room with a circular floor

Let:

1. A be the total surface area of the room
2. V be the total volume of the room
3. T be the total amount of money that will be spent on building the walls of the room.

All money values will be rounded to two decimal places.

### **A room with a square floor**

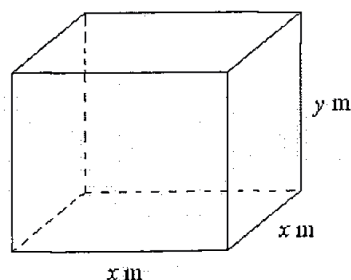

$$\begin{aligned}
 \text{Volume} &= \text{length} \times \text{width} \times \text{height} \\
 &= x^2 y \\
 \therefore 36 &= x^2 y \\
 \therefore y &= \frac{36}{x^2}
 \end{aligned}$$

$$\begin{aligned}
 \text{Total surface area (A)} &= 2x^2 + 4(xy) \\
 &= 2x^2 + 4x\left(\frac{36}{x^2}\right) \\
 &= 2x^2 + \frac{144x}{x^2} \\
 &= 2x^2 + \frac{144}{x}
 \end{aligned}$$

The graph below shows the function  $2x^2 + \frac{144}{x}$ .

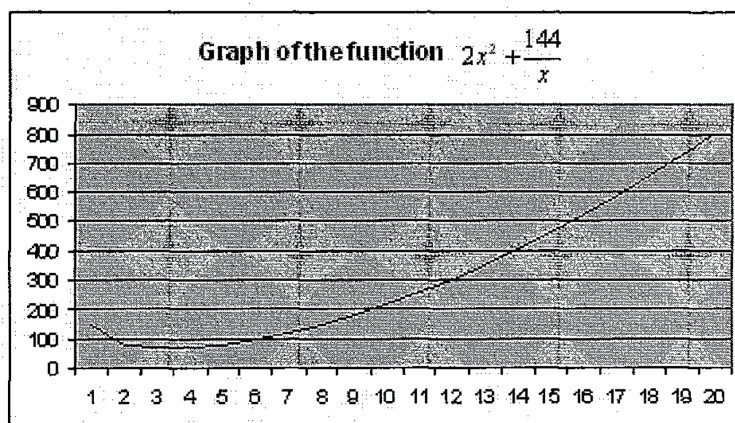

We can see that  $x > 0$  (because it is a length). The shape of the graph as also suggests that when  $A(x) = 0$ , the calculated value would definitely be a minimum. If



the shape of the curve was  I would know that plotting  $A'(x) = 0$  would give me a maximum value.

By using differential calculus and optimization, I can determine what the minimum surface area has to be.

$$A(x) = 2x^2 + \frac{144}{x}$$

$$A(x) = 2x^2 + 144x^{-1}$$

$$A'(x) = 4x - 144x^{-2}$$

$$A'(x) = 4x - \frac{144}{x^2}$$

If  $A'(x) = 0$  then:

$$A'(x) = 4x - \frac{144}{x^2}$$

$$0 = 4x - \frac{144}{x^2}$$

$$-4x = -\frac{144}{x^2}$$

$$\therefore 4x = \frac{144}{x^2}$$

$$4x^3 = 144$$

$$x^3 = 36$$

$$x = \sqrt[3]{36}$$

$$x = 3.01927249$$

$$x = 3.02m$$

This result seems fairly practical, since most humans are less than 2.5m tall. I could also use a sign diagram test to determine whether that value is a minimum.

C4

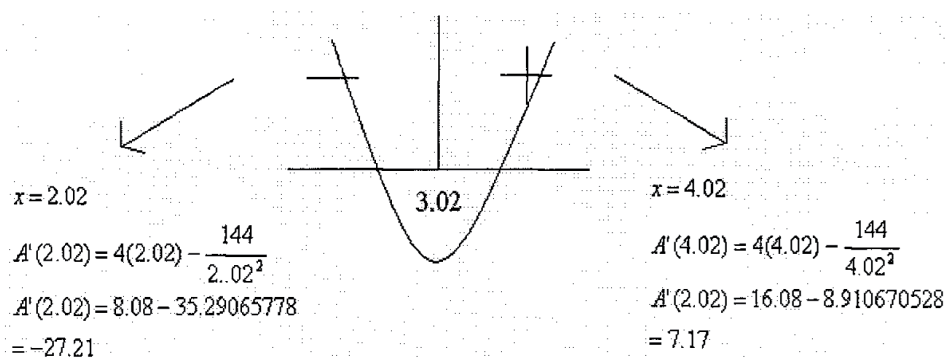

This sign diagram shows us that we have a local minimum and that the value we have for  $x$  is indeed the minimum value.

If  $x = 3.02m$ , we can calculate  $y$ :

$$y = \frac{36}{(3.02)^2}$$

$$y = \frac{36}{9.1204}$$

$$y = 3.947195298$$

$$y = 3.95m$$

Thus our final room would look like this:

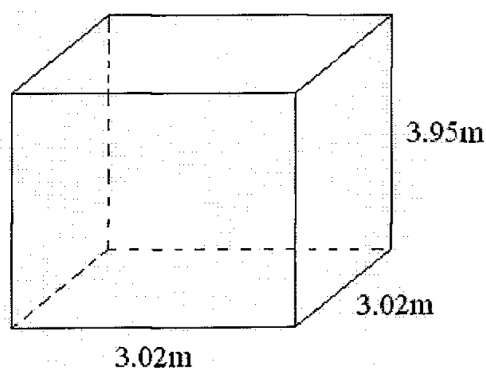

D2

The cost of the walls can be thus calculated:

$$T = (4(3.95 \times 3.02)) \times \$10$$

$$T = 47.716 \times \$10$$

$$T = \$477.16$$

These dimensions seem quite suitable for a room. Since there is no record of any human being wider than 3 metres or 4 metres tall anyone could fit in it. I would have enough room to store large objects such as furniture pieces which creates quite an ideal storage space. The space of  $9.12\text{m}^2$  ( $A = \text{base} \times \text{height}$ ) is a fairly comfortable area, more than enough to avoid claustrophobia. I may not consider this type of structure for the room, but this depends on what the other structures would cost, financially and practically.

#### A rectangular room with a base ratio of 2:1

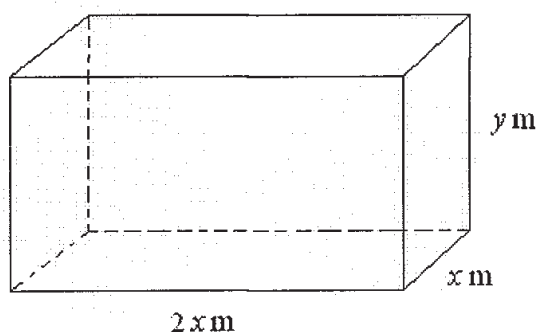

Volume of the box:  $V = 2x^2y$   
 $36 = 2x^2y$

If we wanted to find  $y$  we could use this formula:  $y = \frac{36}{2x^2}$ , simplified to  $y = \frac{18}{x^2}$

The area we would use for the walls would amount to:

$$A = 4x^2 + 6x\left(\frac{18}{x^2}\right)$$

$$A = 4x^2 + \frac{108x}{x^2}$$

$$A = 4x^2 + \frac{108}{x}$$

$$A = 4x^2 + 108x^{-1}$$

Graph the function  $4x^2 + \frac{108}{x}$

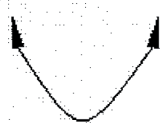
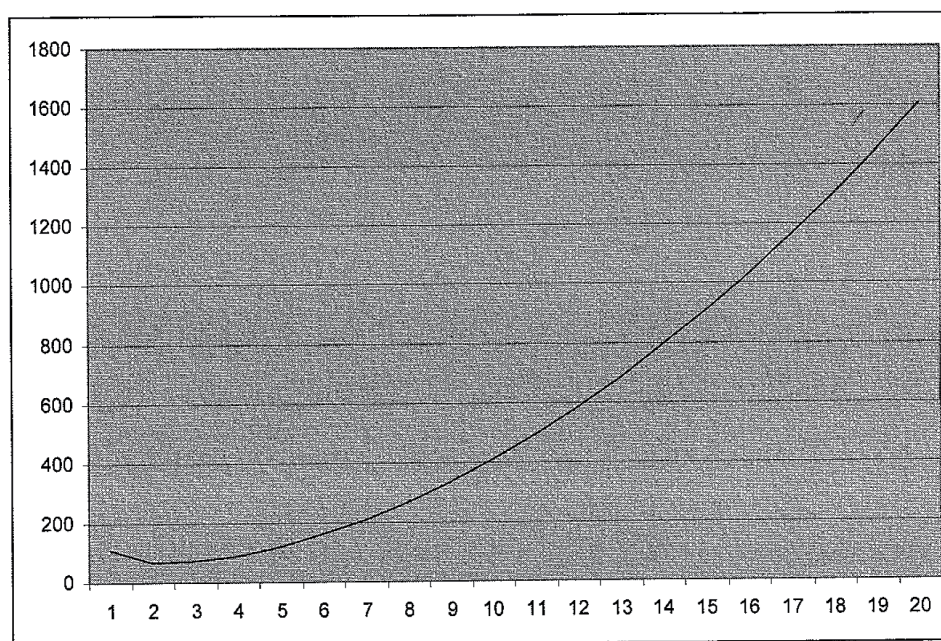

The shape of this graph tells us that when  $A(x)$  is made to equal 0 we will have a minimum value.

$$A(x) = 4x^2 + 108x^{-1}$$

To find the lowest value for  $x$  we need to find the derivative of  $A$ :  $A'(x) = 8x - 108x^{-2}$

$$A'(x) = 8x - \frac{108}{x^2}$$

G1

6

...and find its value at 0 for the lowest value for  $x$ .

$$A'(x) = 8x - \frac{108}{x^2}$$

$$0 = 8x - \frac{108}{x^2}$$

$$-8x = -\frac{108}{x^2}$$

$$\therefore 8x = \frac{108}{x^2}$$

$$8x^3 = 108$$

$$\frac{8x^3}{8} = \frac{108}{8}$$

$$x^3 = 13.5$$

$$x = \sqrt[3]{13.5}$$

$$x = 2.381101578$$

$$x = 2.38m$$

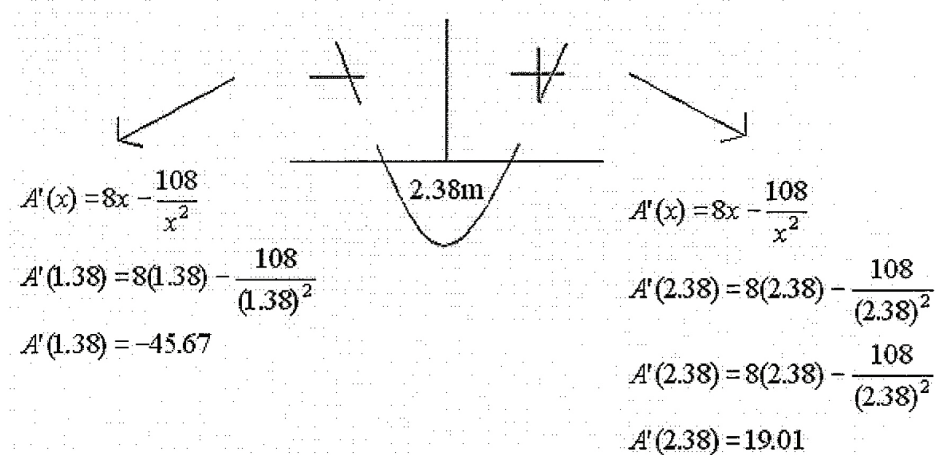

This sign diagram shows us that we have a local minimum and that the value we have for  $x$  is indeed the minimum value.

Now that we know the  $x$  value we can calculate the  $y$  value:

C4

7



$$y = \frac{18}{x^2}$$

$$y = \frac{18}{(2.38)^2}$$

$$y = \frac{18}{5.6644}$$

$$y = 3.177741685$$

$$y = 3.18m$$

Our final dimensions would look like this:

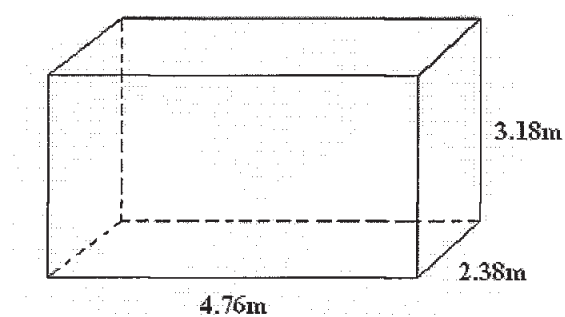

The total cost of the walls:

$$T = (2(4.76 \times 3.18) + 2(3.18 \times 2.38)) \times \$10$$

$$T = (2(15.1368) + 2(7.5684)) \times \$10$$

$$T = (30.2736 + 15.1368) \times \$10$$

$$T = 45.4104 \times \$10$$

$$T = \$454.10$$

This room seems spacious and tall which is great for a storage space. The floor area of  $11.33m^2$  is good if any large pieces of furniture need to be stored. This room would also cost cheaper than the previous room and if I were on a tight budget I would choose this room. Since no living human being has ever measured taller than 3.18m or wider than 2.38m, anyone would be able to fit. There is one other type of room to consider before making a final decision.

D2

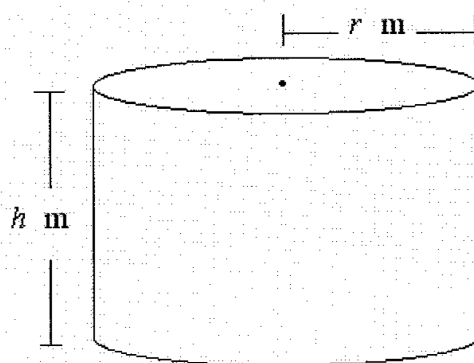
**A cylindrical room with a circular base**

$$\text{Volume} = \pi r^2 h$$

The height of the room can be measured as thus:

$$36 = \pi r^2 h$$

$$h = \frac{36}{\pi r^2}$$

This is important because we need this value of  $h$  in our next equation which measures the total surface area  $A$ :

$$A = 2\pi r^2 + 2\pi r h$$

$$A = 2\pi r^2 + 2\pi r \left( \frac{36}{\pi r^2} \right)$$

$$A = 2\pi r^2 + \frac{72\pi r}{\pi r^2}$$

$$A = 6.283r^2 + \frac{72r}{r^2}$$

$$A = 6.283r^2 + \frac{72}{r}$$

By plotting another graph we can check to see if  $A'(r)$  would be a minimum:

G1

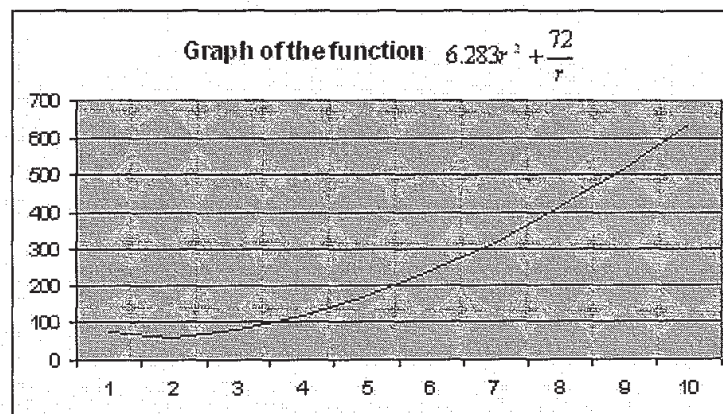

Again, the shape of the graph shows us that when  $A'(r) = 0$  we will be given a minimum value.

With that formula we can use differential calculus to find the derivative of  $A(r)$ :

$$A(r) = 2\pi r^2 + \frac{72}{r}$$

$$A(r) = 2\pi r^2 + 72r^{-1}$$

$$A'(r) = 4\pi r - 72r^{-2}$$

$$A'(r) = 4\pi r - \frac{72}{r^2}$$

And thus the minimum surface area of the curved surface by making  $A'(r) = 0$ :

$$A'(r) = 4\pi r - \frac{72}{r^2}$$

$$0 = 4\pi r - \frac{72}{r^2}$$

$$-4\pi r = -\frac{72}{r^2}$$

$$\therefore 4\pi r = \frac{72}{r^2}$$

$$4\pi r^3 = 72$$

$$\pi r^3 = 18$$

$$r^3 = 18/\pi$$

$$r^3 = 5.729577951$$

$$r = \sqrt[3]{5.729577951}$$

$$r = 1.789400458$$

$$r = 1.79\text{m}$$

To make sure that this is the minimum value we need to use the sign diagram test:

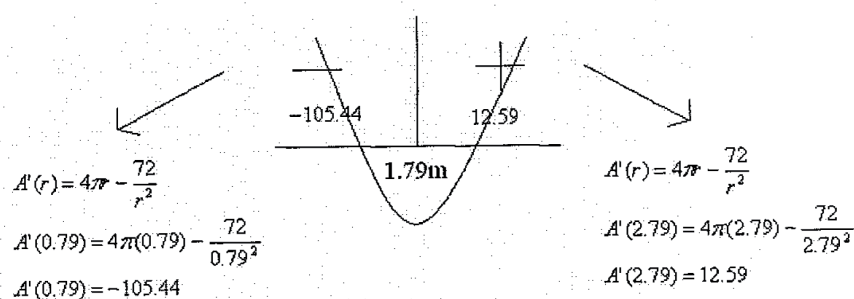

This sign diagram shows us that we have a local minimum and that the value we have for  $x$  is indeed the minimum value.

Now that we have our  $r$  value we can calculate what  $h$  would be:

C4

$$h = \frac{36}{\pi^2}$$

$$h = \frac{36}{\pi(1.79)^2}$$

$$h = \frac{36}{3.2041\pi}$$

$$h = 3.576403952$$

$$h = 3.58m$$

We could perform another sign diagram test, but knowing that  $r$  is already the minimum value, we would receive this for  $h$  as well.

Our total surface area of the walls now with  $r$  and  $h$  would be:

$$A = 2\pi rh$$

$$A = 2\pi(1.76)(3.58)$$

$$A = 39.58909398$$

$$A = 39.60m^2$$

And we can calculate how much I would spend for the walls alone:

$$T = 39.60m^2 \times \$10$$

$$T = \$396.00$$

This is what the final room would look like:

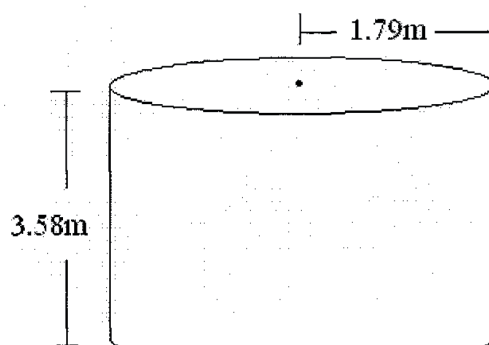

C4

These proportions seem much more practical than the previous room. The price is also cheaper and if I were on a limited budget I would consider taking the cheapest option. The advantage that this room has is that its floor area at  $17.67\text{m}^2$  is larger therefore I have more storage space. Because of the larger storage capacity I can see why oil or water companies would choose cylindrical tanks for storage. As a storage room, I notice that the curved edges of the walls may make storing large objects with straight edges difficult and result in wasted space. There is, however, one more type of room to consider before I make a final decision.

### Summary of Results

Room structure	Height (m)	Width (m)	Length (m)	Floor Area ( $\text{m}^2$ )	Cost of the walls
Square	3.95	3.02	3.02	9.12	\$477.16
Rectangular	3.18	2.38	4.76	11.33	\$454.10
Cylindrical	3.58	3.58	-	10.07	\$396.00

Looking at these results I am very much inclined to investing into a cylindrical room because it is the cheapest of the three, but if I truly wanted the largest floor space I would choose a rectangular room. I would not consider building a square room because it is the most expensive yet yields the lowest floor area. For the sake of straight edged furniture and/or other objects I would use the rectangular room as my final decision.

But since these results are rounded to two decimal places I cannot say that the cost of the walls is accurate. If I were on a strictly limited budget and wanted to save every single penny I could, I would not have rounded my figures so liberally. I would have rounded my values to at least five decimal places, but it is physically difficult to achieve measuring or handling lengths of extreme accuracy.

The value of  $\pi$  has also affected my results because of my graphics calculator; despite having over one thousand digits the calculator only uses 10, and as I used this value in

D2

E0

my calculations and later rounded the answer to make further calculations easier, I have distanced myself even further from accurate measurements. One way I could prevent this would be to use several calculators instead of a single one to help me determine an accurate answer; for example, the value of  $\pi$  in my calculator has only ten decimal places. The Windows calculator gives  $\pi$  with thirty decimal places!

I found it quite surprising that the two quadrilaterals had a smaller area than the cylindrical room. I hypothesized that I would consider the rectangular room because of its frequent usage today. I have seen minimal cylindrical buildings but after having done this project I wonder why it is less employed if it has a larger floor area and costs cheaper to make. However, this may not necessarily be true; a person could employ a cheaper or more expensive material than I chose, and prices always seem to be fluctuating and inconsistent. I also cannot generalize upon these three results; if I wanted to take this project further I would consider measuring pyramids and cones, or even spheres. That way I would have more options to consider rather than having to stick to three.

Although it is a lengthy process, using both differential calculus and optimization aids anyone willing to use it, with quite satisfactory results.

E0

14